



User Manual

DC-5100 Laminator



Important Safety Instructions (English)

Read the following instructions thoroughly before starting up your printer.

- The device and power supply must all times be easily accessible.
- Never carry out maintenance or repair work yourself. Always contact a Dascom qualified service technician.
- Keep this user guide in a place which is easily accessible at all times.
- Place the printer on a solid and level base for reliable operation.
- Never place the printer in the vicinity of inflammable gas or explosive substances.
- Ensure the printer is connected to a socket with the correct voltage.
- Always disconnect the printer from power source before opening the device to perform maintenance work or remedy errors.
- Do not expose the printer to high temperature, direct sunlight, or dust.
- Keep all liquids away from the printer.
- Protect the printer from shock, impact and vibration.
- Make sure that both printer and computer are switched off before connecting the data cable.
- The print head will become very hot during printing; avoid contact with the print head after printing has finished.
- Do not perform any operation or action in any way other than those provided in this manual. When in doubt, contact your Dascom dealer or customer support.

Wichtige Sicherheitshinweise (German)

Lesen Sie bitte diese Sicherheitshinweise durch, bevor Sie den Drucker in Betrieb nehmen.

- Das Gerät und die Netzsteckdose müssen jeder Zeit leicht zugänglich sein.
- Führen Sie Wartungsarbeiten und Reparaturen keinesfalls selbst aus, sondern verständigen Sie immer einen qualifizierten Servicetechniker.
- Bewahren Sie diese Dokumentation an einem jederzeit zugänglichen Ort auf.
- Den Drucker auf stabilem und ebenem Untergrund so aufstellen, dass er nicht zu Boden fallen kann.
- Stellen Sie den Drucker keinesfalls in der Nähe von leicht entzündlichen Gasen oder explosiven Stoffen auf.
- Den Drucker nur an eine Steckdose mit der richtigen Spannung anschließen.
- Wenn Sie den Drucker vom Netz trennen wollen, den Drucker ausschalten und immer den Netzstecker an der Steckdose ziehen.
- Den Drucker weder hohen Temperaturen noch direktem Sonnenlicht und Staub aussetzen.
- Keine Flüssigkeiten mit dem Drucker in Berührung bringen.
- Den Drucker keinen Erschütterungen, Stößen oder Vibrationen aussetzen.
- Sicherstellen, dass der Drucker und der Computer ausgeschaltet sind, bevor das Datenkabel angeschlossen wird.
- Der Druckkopf wird während des Druckens heiß. Vor dem Berühren deshalb einige Zeit abkühlen lassen.
- Weichen Sie bei der Bedienung des Druckers nicht von den Anweisungen in der Dokumentation ab. Bei Unklarheiten wenden Sie sich bitte an Ihren Händler oder Ihren Kundendienst.

Consignes importantes de sécurité (French)

Lire attentivement les instructions suivantes avant de mettre l'imprimante en service.

- Le dispositif et la prise principale doivent toujours être accessibles facilement.
- Ne jamais effectuer soi-même les travaux d'entretien et de réparations. Contacter toujours un dépanneur qualifié.
- Placer l'imprimante sur un support stable de façon à ce qu'elle ne puisse pastomber.
- Ne jamais placer l'imprimante à proximité de sources de gaz aisément inflammables ou de substances explosives.
- Ne connecter l'imprimante à une prise que lorsque la tension est correcte.
- Pour déconnecter l'imprimante de l'alimentation principale, mettre l'imprimante hors tension et toujours débrancher le connecteur secteur de la prise murale.
- Ne pas exposer l'imprimante à des températures élevées, à la lumière directe du soleil ou à la poussière.
- Ne pas mettre l'imprimante en contact avec des liquides.
- Ne pas exposer l'imprimante à des chocs, impacts ou vibrations.
- S'assurer que l'imprimante et l'ordinateur sont hors tension avant de connecter le câble de données.
- La tête d'impression est brûlante pendant l'impression. C'est pourquoi laissez-la refroidir quelques instants avant d'y toucher.
- N'exécutez aucune opération ni action d'une autre manière que celle indiquée dans ce manuel. En cas de doute, veuillez contacter votre distributeur ou service après-vente.

Indicazioni di sicurezza importanti (Italian)

Prima di mettere in funzione la stampante, leggere attentamente le seguenti indicazioni.

- Il dispositivo e la presa di corrente devono essere sempre facilmente accessibili.
- Non eseguire mai da sé gli interventi di manutenzione e riparazione, ma rivolgersi sempre a un tecnico di assistenza qualificato.
- Conservare le presenti istruzioni per l'uso in un luogo sempre accessibile.
- Collocare la stampante su una superficie stabile, per evitare che cada a terra.
- Non collocare la stampante in prossimità di gas facilmente infiammabili o di sostanze esplosive.
- Collegare la stampante a una presa di corrente con tensione adeguata.
- Per scollegare la stampante dalla rete di alimentazione, spegnere la stampante e disinserire sempre il connettore di rete dalla presa.
- Non esporre la stampante ad elevate temperature né alla luce solare diretta e alla polvere.
- Evitare il contatto della stampante con liquidi.
- Non esporre la stampante a colpi, scosse o vibrazioni.
- Verificare che la stampante e il computer siano spenti prima di collegare il cavo di trasmissione dati.
- Durante la stampa, la testina si surriscalda notevolmente. Prima di toccarla, se necessario opportuno quindi lasciarla raffreddare qualche istante.
- Non eseguire alcuna operazione o azione se non nella maniera descritta nel presente manuale. In caso di dubbio, contattare il rivenditore o dalla società incaricata dell'assistenza.

Instrucciones de seguridad importantes (Spanish)

Lea las siguientes instrucciones con esmero antes de poner la impresora en servicio.

- El dispositivo y la toma de corriente deben estar ubicados de forma que sea fácil acceder a ellos.
- Nunca lleve a cabo trabajos de mantenimiento o reparación Ud. mismo, sino consulte a un técnico de servicio calificado.
- Guarde las presentes instrucciones de servicio en un lugar de fácil acceso en cualquier momento.
- Ponga la impresora sobre un superficie estable de manera que no pueda caer al suelo.
- Nunca coloque la impresora en la vecindad de gases inflamables o sustancias explosivas.
- Asegure conectar la impresora sólo a un enchufe con un voltaje correcto.
- Cuando quiera desconectar la impresora de la red, apague la impresora y siempre hale de la clavija de alimentación del enchufe nunca del cable.
- No exponga la impresora a temperaturas altas, a la luz solar directa y al polvo.
- No ponga la impresora en contacto con fluidos.
- Nunca exponga la impresora a sacudidas, choques o vibraciones.
- Asegúrese de que la impresora y el ordenador estén apagados antes de conectar el cable de datos.
- La cabeza de impresión se pone muy caliente durante la impresión. Por lo tanto, Déjela enfriarse algún tiempo antes de tocarla.
- No permita que se realice cualquier operación o acción de una forma diferente a lo que se señala en el manual. En caso de duda, póngase en contacto con su comerciante o con su servicio post-venta.

Правила по технике безопасности. (Russian)

Прочитайте, пожалуйста, инструкцию по технике безопасности перед включением в работу принтера.

- Устройство и розетка должны быть всегда легко доступна.
- Не выполняйте технические работы и ремонт техники самостоятельно, но сообщайте о неисправностях квалифицированным сервисным техникам.
- Данная инструкция должна быть всегда доступна каждому пользователю.
- Установите принтер на ровном и стабильном месте так, чтобы он не смог упасть на пол.
- Ни в коем случае не ставьте принтер вблизи легко воспламеняющихся газов и взрывчатых веществ.
- Включайте принтер в розетку только с соответствующим напряжением.
- Если Вы хотите отключить принтер от напряжения, сначала выключите принтер сам и затем выньте штекер из розетки.
- Берегите принтер от нагревания, от попадания на него прямых солнечных лучей и пыли.
- Не допускайте попадания жидкости на принтер.
- Нельзя подвергать принтер тряске, ударам и вибрации.
- Убедитесь, что принтер и компьютер выключены, только после этого соедините принтер с компьютером.
- Печатающая головка нагревается во время работы принтера. Поэтому подождите какое-то время, прежде чем дотронуться до нее.
- Пользуйтесь принтером так, как это написано в документации. Если у Вас возникают неясности, обращайтесь с вопросами к Вашим продавцам или в сервисный центр.

Instruções Importantes sobre Segurança (Portuguese)

Leia as instruções de segurança antes de usar a impressora.

- A impressora e a tomada devem ser facilmente em todos os momentos acessíveis.
- Consulte sempre um técnico qualificado para executar uma reparação .
- Coloque a impressora sobre uma base sólida e nivelada, para que ela não sofra quedas.
- Jamais instale a impressora nas proximidades de lugares onde haja gás inflamável ou substâncias explosivas.
- Assegure-se de conectar a impressora à tomada elétrica com a voltagem apropriada.
- Quando desligar a impressora da rede, desligue sempre a impressora e retire o cabo da tomada.
- Não exponha a impressora a temperaturas altas ou luz solar direta.
- Não aproxime substâncias líquidas da impressora.
- Proteja a impressora de choques, impactos e vibrações.
- Desligue a impressora e o computador antes de conectar o cabo da rede.
- A cabeça da impressora pode ficar muito quente . Portanto, espere algum tempo antes de tocá-la.
- Não faça nenhuma operação ou ação além das recomendadas neste manual. Em caso de dúvida, contate seu revendedor ou companhia de serviço.

Önemli Güvenlik Talimatları (Turkish)

Lütfen, yazıcıyı işleme geçirmeden önce bu güvenlik talimatlarını bütünüyle dikkatle okuyun.

- Cihaz ve elektrik prizinin her zaman kolayca erişilebilir olması gerekir.
- Bakım ve tamir çalışmalarını kesinlikle ve hiçbir surette kendi başınıza yapmayın; her zaman kalifiye bir uzman servis-teknisyenine haberverin.
- Yazıcıyı, üzerinden yere düşmesi mümkün olmayacak sabit ve düz bir zemine yerleştirin.
- Yazıcıyı kesinlikle ve hiçbir surette kolayca yanabilecek gaz veya patlayıcı maddeler içeren nesnelere yakınına koymayın.
- Yazıcı akım kablosunu sadece doğru gerilime sahip bir prize takın.
- Yazıcıyı şebeke ağından ayırmak istediğinizde, yazıcıyı kapatın ve ağ-fişini her zaman prizden çıkartın.
- Yazıcıyı ne yüksek ısı ne de doğrudan güneş ışığına ve toza mâruz kalan mekânlarda bulundurun.
- Yazıcı hiçbir sıvı maddeyle temasta olmamalıdır.
- Yazıcı hiçbir sarsıntıya, darbeye veya titreşime mâruz kalmamalıdır.
- Veri kablosu bağlanmadan önce hem yazıcının hem de bilgisayarın kapalı olduklarından emin olmalısınız.
- Yazıcının başı basma esnasında yüksek ısıya ulaşıyor. Bu yüzden lütfen dokunmadan önce kısa süre soğumasını bekleyin.
- Yazıcının işletimi ve kullanımında bu dokümantasyondaki talimatların hiç dışına çıkmayın. Sorunlu görünen hususlarda lütfen imâlatçınıza veya müşteri hizmetleri servisimize başvurun.

TRADEMARK ACKNOWLEDGEMENTS

“Windows”, “Windows 7”, “Windows 8”, “Windows 10”, “Windows XP” and “Windows Vista” are trademarks of Microsoft Corporation.

All other product names and company names appearing in this manual are the registered trademarks or trademarks of their respective holders.

Symbol Description

The symbols in this manual are identified by their level of importance, as defined below. Read the following carefully before handling the product.



CAUTION: Provides information that must be observed to prevent damage to the equipment or data loss.



NOTE: Advises you of information that is essential to complete a task.



CAUTION: Keep your body away from moving part.



CAUTION: Hot ! Do not touch the parts till the printer has been switch off in half hour, otherwise it will hurt your fingers.

About This Manual

This manual provides information that describes the basic operation, enabling safe and correct use to the operators of DC-5100 Laminator.

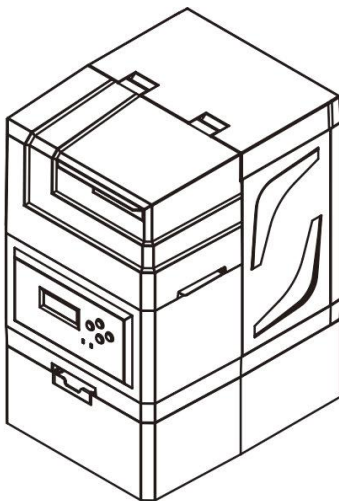

TABLE OF CONTENTS

CHAPTER 1 INTRODUCTION.....	1
1.1 Unpacking.....	1
1.2 Placing the Laminator.....	2
1.3 Laminator Components.....	3
1.4 Keys and LEDs.....	5
1.5 Attaching Power.....	6
1.6 Connecting to Computer.....	8
CHAPTER 2 INSTALLATION.....	9
2.1 Installing the Film.....	9
2.2 Loading the Card.....	12
2.3 Changing the Setting.....	13
2.4 Updating the Firmware.....	16
2.5 Optimizing the Laminate Quality.....	17
CHAPTER 3 NORMAL MODE AND USER MODE.....	18
3.1 Normal Mode.....	18
3.2 User Mode.....	19
3.3 Major Menus.....	21
CHAPTER 4 TROUBLESHOOTING.....	25
4.1 Warning Messages and Troubleshooting.....	25

CHAPTER 1 INTRODUCTION

1.1 Unpacking

Open the package, take out the laminator and remove the protect material. Check if the parts and accessories in the box are complete as the following picture. If found any damage, please contact the carrier and notify your authorized Dascom re-seller to realize the steps to be taken.

Please keep the complete original package for future use.

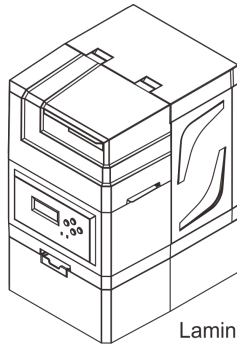

Laminator

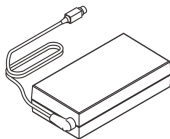

Power Adapter

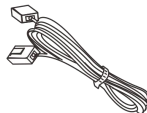
Installation
Guide

USB Cable

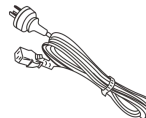

Power Cord



The package contents vary with different customized order requirements.

1.2 Placing the Laminator

Before installing the laminator, first of all to determine a suitable place to place it.

- Do not place the laminator on an unstable table, on a slant, or any place where there is excessive vibration.
- Do not place the laminator in a damp or dusty location.
- Connect to stable power supply, avoid using the same power supply with high power appliances such as refrigerators.
- Before unplug the power cord, turn off the laminator. Place the laminator close to the main socket for easy use.

1.3 Laminator Components

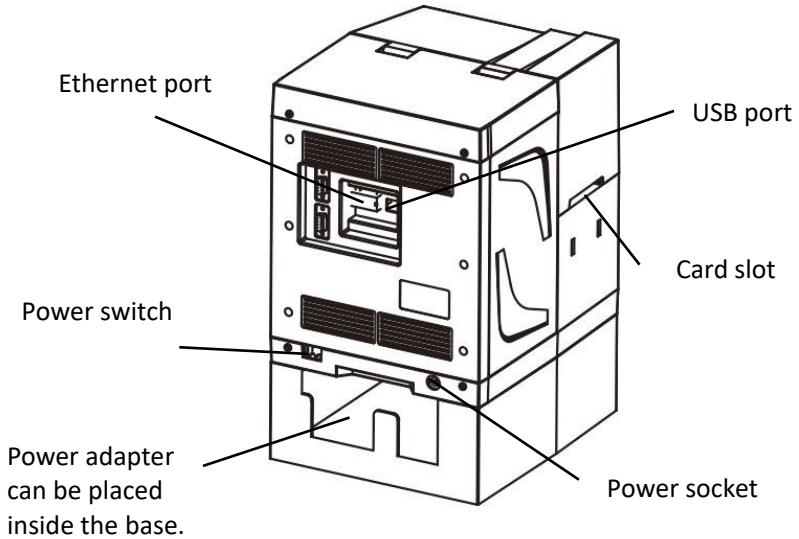
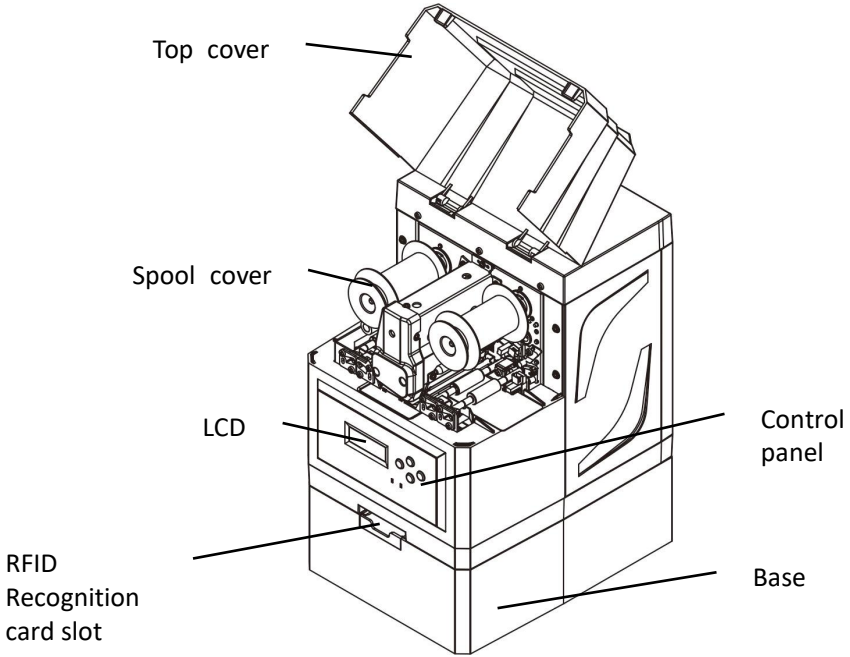

Part name	Function
Control panel	Includes the keys, LED indicators and LCD Panel, for operating the laminator.
Top cover	Open to install the film.
Port	Connect to the computer via USB port or Ethernet port.
Power socket	Used to connect the power adapter.
Power switch	Turns on and off the laminator.
RFID Recognition card slot	Used to place RFID recognition tag that is attached to the film.

1.4 Keys and LEDs

Key

There are four keys.

Position	Function
Left 【Menu/Exit Key】	Enter or exit current setting.
Right 【Set Key】	Confirm current setting.
Up/Down	Select settings or parameters up and down.

LED and buzzer

There are two LED lights: blue means ready, red means error.

The following combinations of different lights and buzzer show different statuses of the laminator.

Laminator Status	Ready LED (Blue)	Error LED (Red)	Buzzer
Initiating	Flashes	Off	/
Heating			
Cooling			
Ready	On	Off	/
Menu setup	On	Off	/
Laminating	Flashes	Off	/
Warning	Flashes	Off	/
Error	Off	On	Buzz constantly

LCD

User can view the status of laminator and/or modify the parameters of laminator via the LCD.

1.5 Attaching Power

■ Connecting the Power Cables

- (1) Make sure the laminator is powered off. ①
- (2) Connect the power adapter to the laminator. ②
- (3) Connect the power cord to the power adapter. ③
- (4) Connect the power cord to the power socket. ④

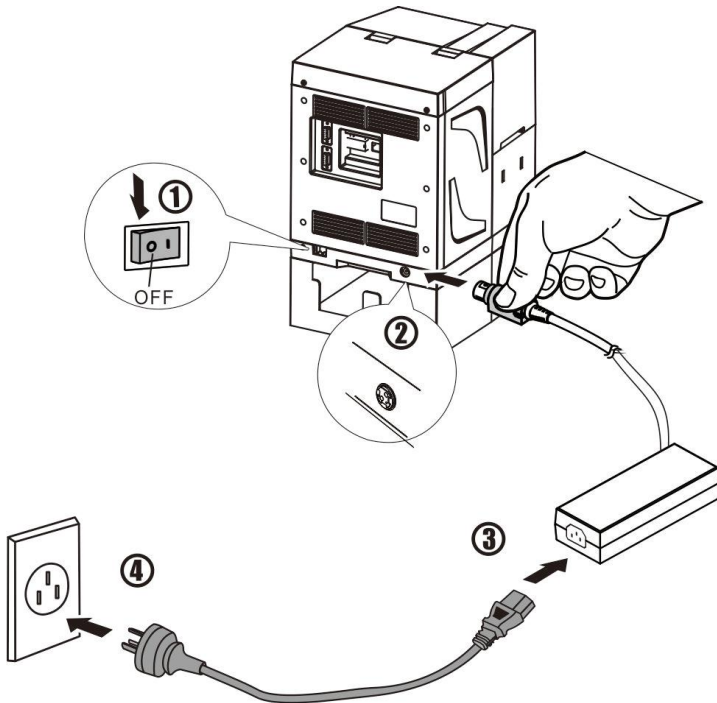

■ Power on and Power off

Press the power switch: "I", switch on the laminator.

Press the power switch: "O", switch off the laminator.

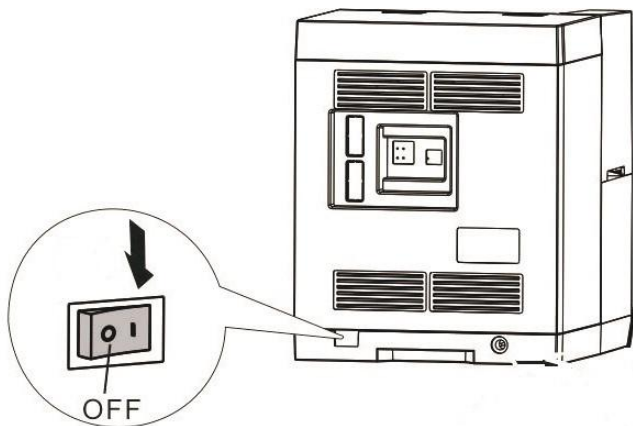

Please disconnect the power cord if the laminator will not be used for a long time. If the laminator is used with DASCOM retransfer equipment, turn on the laminator before turning on the retransfer equipment.

1.6 Connecting to Computer

The standard On-board ports of this laminator are a USB port and an Ethernet port.

- (1) Ensure your laminator is switch off.
- (2) Insert the interface cable into the corresponding port.
- (3) Connect the other end of the interface cable to the host computer.

■ Connecting to Computer via USB port

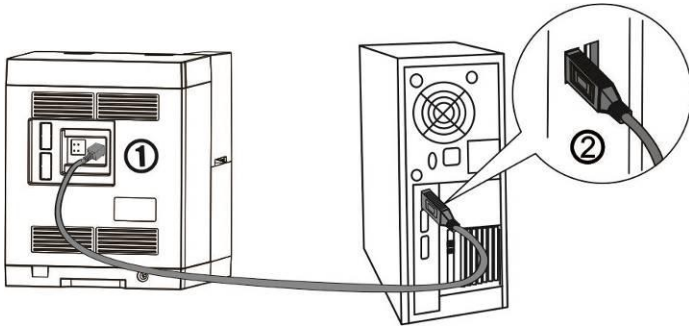

■ Connecting to Computer via Ethernet port

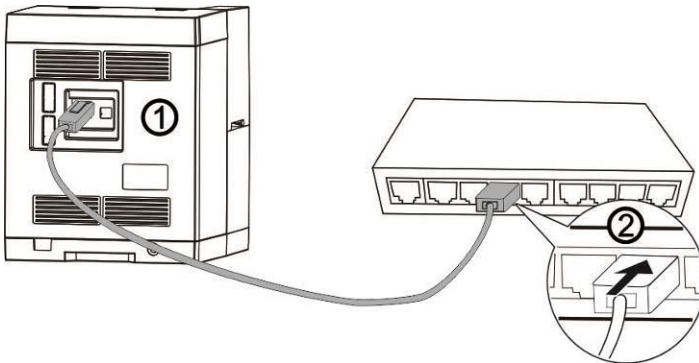

CHAPTER 2 INSTALLATION

2.1 Installing the Film



Turn off the laminator before installing the film.

- 1、 ① Open the top cover.
- ② Take out 2 spool covers.

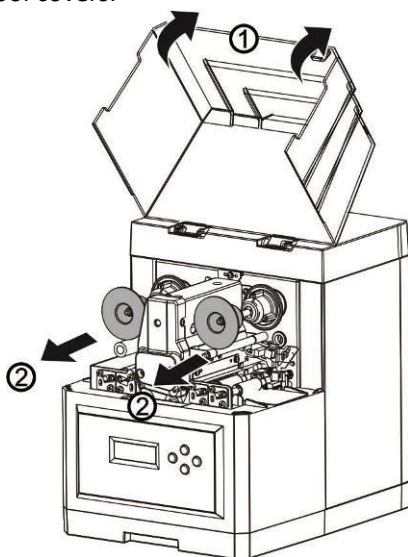

- 2、① Locate the new film into 2 spool poles. (Note: The one facing the laminator on the left side is the rewind pole.)
- ② Put 2 spool covers back in place.

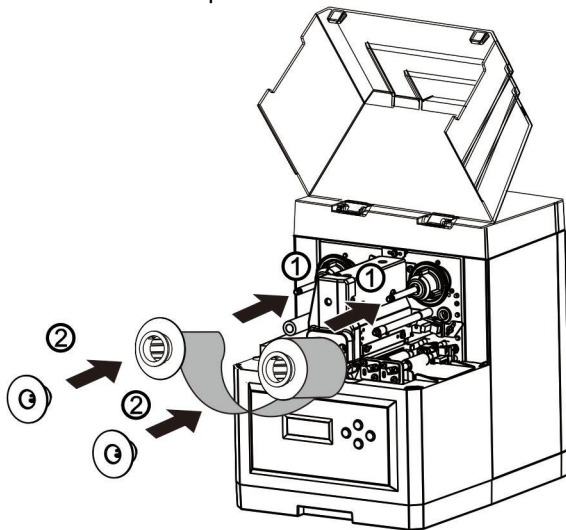

- 3、① Adjust the film according to the arrow direction as shown in below figure, ensure the film passes through the guiding axis, heating module and guiding roller without wrinkles.
- ② Close the top cover.

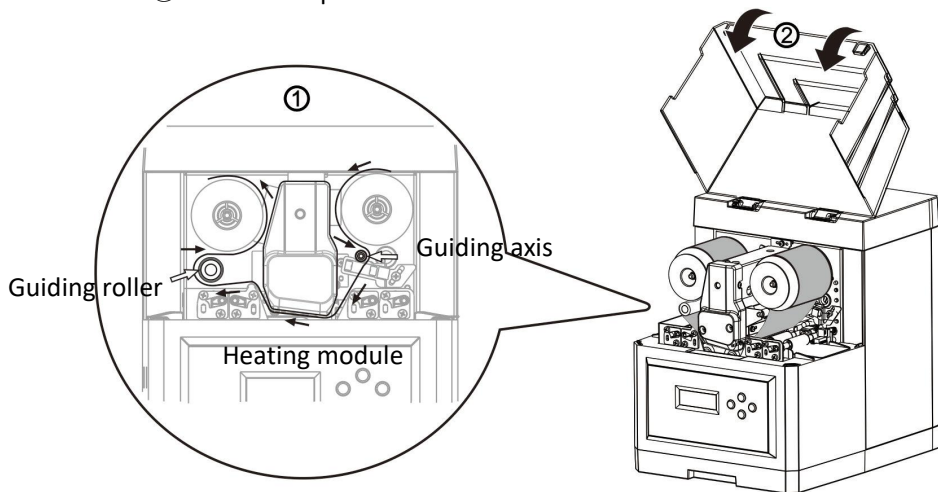

- 4、 Place RFID recognition tag that is attached to the film into the card slot on the base (to identify whether the used film is genuine from Dascom), and then push in the card slot.

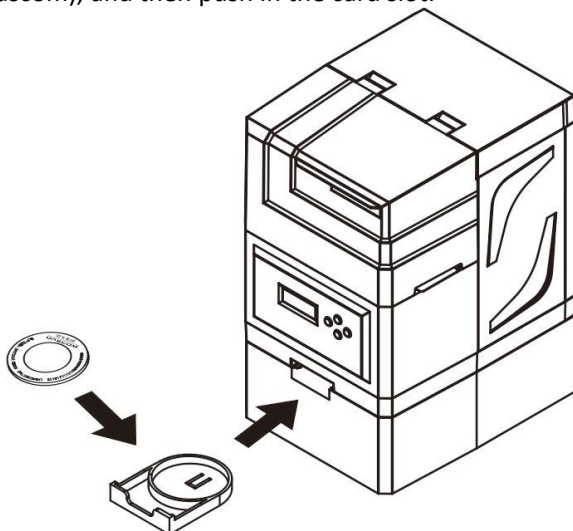

2.2 Loading the Card

Load the card through the slot, one at a time.

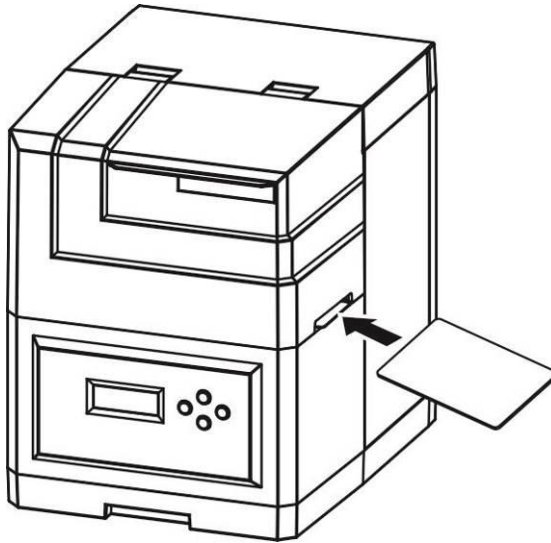

2.3 Changing the Setting

Directly click the setup tool to change the settings. No installation is needed.

Menu setup

When the laminator is in the normal mode, **【Auto detect】** and **【HID device】** are selected, click **【Activate Port】** to enter menu setup, as shown below.

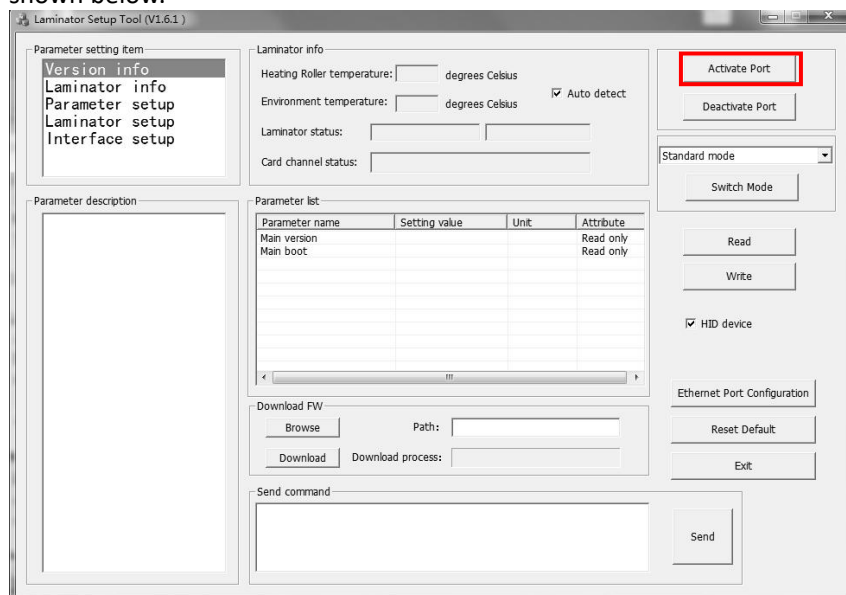

How to change the parameters in the menu via the setup tool :

- 1、 Select the required setting item in the **【Parameter setting item】** .
- 2、 Select the required parameter in the **【Parameter list】** , and double click the corresponding **【Setting value】** to do the change. When changing the parameter, please pay attention to the annotation for the setting range.

Parameter setting item



Parameter list

Parameter list:

Parameter na...	Setting value	Unit	Attribute
Laminate mode	Mode 1		Read and write
Heating roller t...	150	°C	Read and write
Laminate speed	15	mm/sec	Read and write
Film feed speed	25	mm/sec	Read and write
Film laminate p...	0.0	mm	Read and write
Card laminate ...	0.0	mm	Read and write
Laminate end ...	0.0	mm	Read and write
Black mark det...	Invalid		Read and write
Black mark det...	25	mm/sec	Read and write
Auto card in ti...	0	sec	Read and write

Parameter annotation

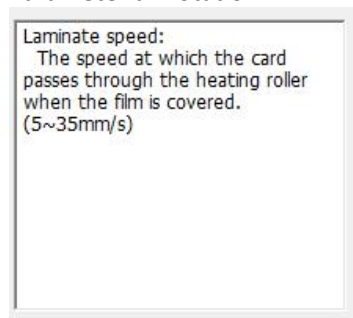

3、Click **【Write】** to save the change. You can also click **【Read】** to view the parameters in current menu.

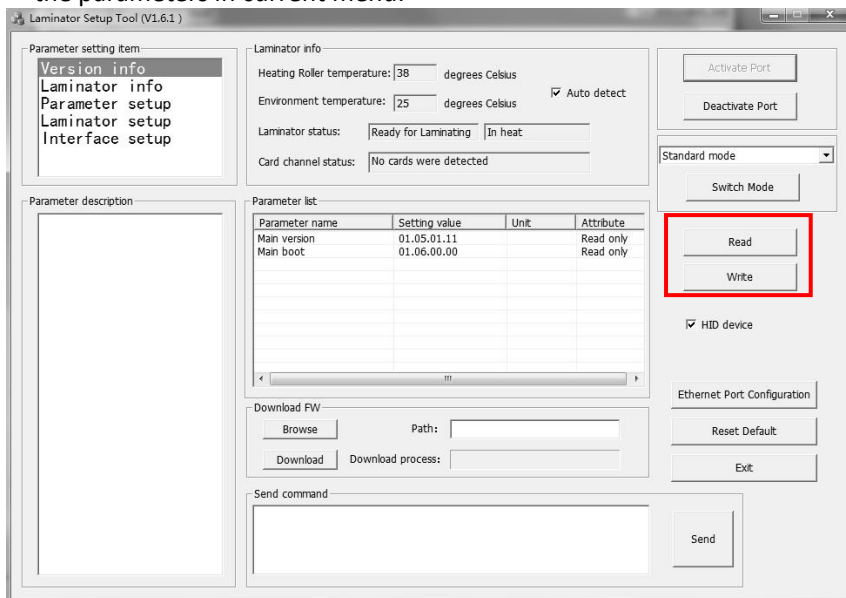

2.4 Updating the Firmware

Holding **【Menu】** and **【Setting】** keys while powering on the laminator, to enter FW update mode.

LCD will shown as below.



How to update the FW via the setup tool :

- 1、 Cancel the selection of **【Auto detect】** .

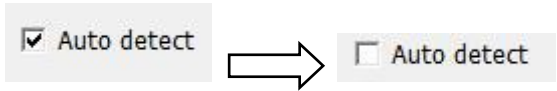

- 2、 Click **【Activate port】** .
- 3、 Click **【Browse】** to select the installation path.
- 4、 Click **【Download】** to start updating FW. When the update process is complete, the laminator will restart automatically.

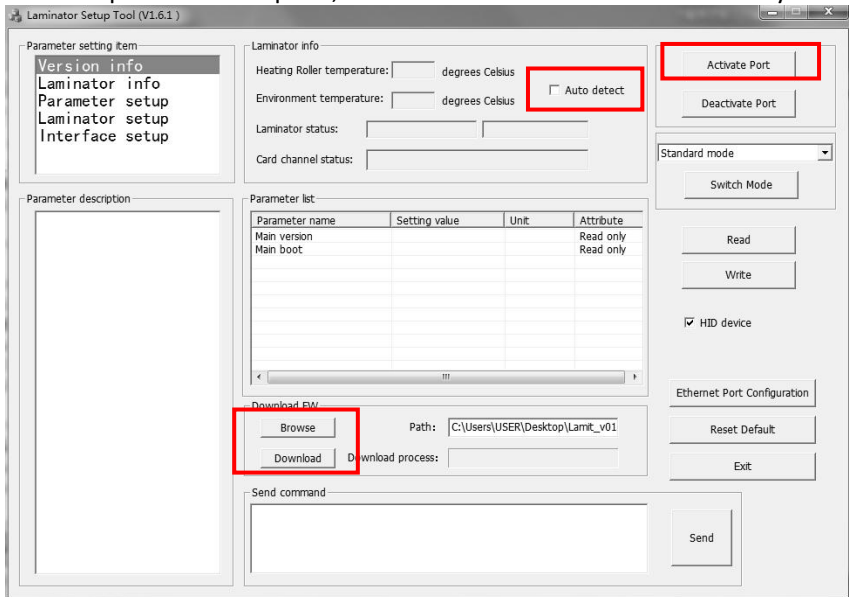

2.5 Optimizing the Laminate Quality

To optimize the laminate quality, you can change the heating roller temperature and laminating speed according to the type of the card, via LCD panel or setup tool.

1、 Setup the heating roller temperature:

- ① Change Normal Mode to User Mode (please refer to Chapter 3.2).
- ② Press **【▼】** key until the LCD displays **【Laminate Parm Setup】** , and then press the right key.
- ③ Press **【▼】** key until the LCD displays **【Heater Temp】** . Press the right key.
- ④ Press **【▼/▲】** key to change current temperature.

2、 Setup the laminate speed:

- ① Change Normal Mode to User Mode (please refer to Chapter 3.2).
- ② Press **【▼】** key until the LCD displays **【Laminate Parm Setup】** , and then press the right key.
- ③ Press **【▼】** key until the LCD displays **【Laminate Speed】**. Press the right key.
- ④ Press **【▼/▲】** key to change current speed.

CHAPTER 3 NORMAL MODE AND USER MODE

You can change between **Normal Mode** and **User Mode** when the laminator is operating.

This section outlines the differences between these two modes and how to switch from one to the other.

3.1 Normal Mode

Normal mode: After start up, the laminator goes into Normal Mode in which the laminator can laminate cards.

In this mode, after you press the **▼Key** for 1 second, the LCD displays the heating roller temperature and environment temperature, as shown below.

Heater Temp:	150°C
Env Temp:	25°C

Normal Mode Message List:

Initialize	The laminator undergoes system diagnostic and initialization. Cards remaining in the laminator from a previous irregular session will be ejected.
Heating	After initialization, the heating roller is heating up to the specified temperature for laminating.
Cooling	When the heating roller temperature is higher than the setting value, the heating roller will cool down.
Ready to laminate	The laminator is awaiting host requests or commands.
Laminating	The laminator is implementing the laminating operation.
Power Save Mode	The laminator is in an energy saving state.

3.2 User Mode

User Mode allows changing the parameters and checking the status.

How to change from Normal Mode to User Mode:

After initialization, LCD displays [READY]. Press **Menu/Exit** Key for 1 second then release it. The LCD changes its display to [Version Info], which is the entry menu in User Mode, as shown below.

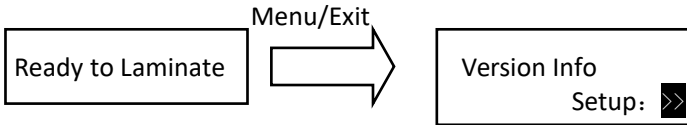

How to return to Normal Mode from User Mode:

Consecutively press **Menu/Exit Key** until the LCD shows [Quit the Menu]. Then press **Set Key** to return to Normal Mode, as shown below.

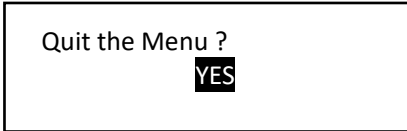

Function of four keys in User Mode:

- **【Menu/Exit Key】** : enter the menu or back to its parent menu
- **【▲】** : previous item
- **【▼】** : next item
- **【Set Key】** : an affirmative response to the second line in the LCD

Consecutively pressing ▼/▲ keys scrolls through the various menus. It doesn't mater which arrow key is pressed since the menu loop around. But when the desired menu is displayed, press the **Set key**.

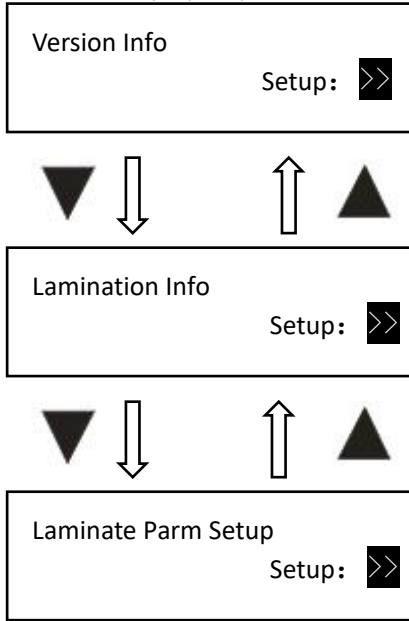

When **SET: >>** appears on the second line of the menu, pressing **Set Key** enters available sub-menus or parameter values. As shown below, the right menu is the sub-menu of the left one.

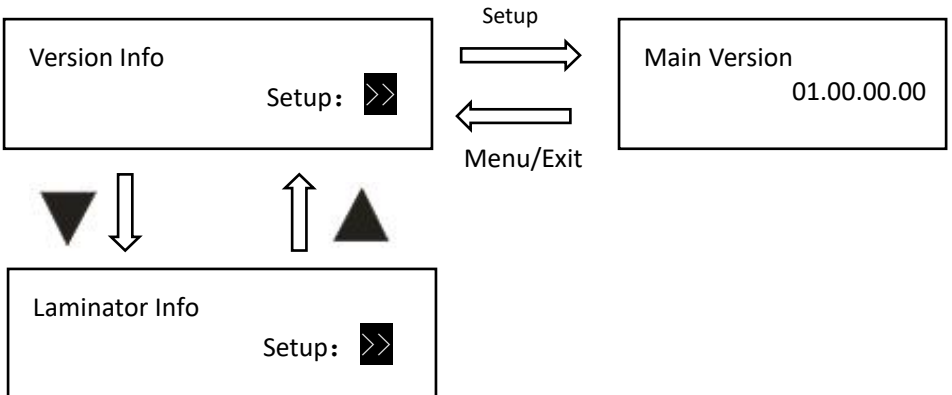

Consecutively press **Menu/Exit Key** until the LCD shows [Quit the Menu]. Then press **Set Key** to return to Normal Mode, as shown below.

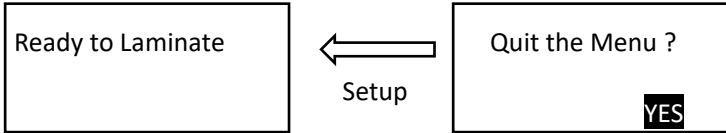

Set Key must be pressed to save the newly changed value. Directly pressing **Menu/Exit Key** or switching off the laminator will not save any newly changed value(s).

3.3 Major Menus

- Version Info
- Lamination Info
- Laminate Parm Setup
- Laminator Setup
- Interface Setup
- Reset Default

■ Version Info

- ◆ Main Version: Version number of Main Firmware.
- ◆ Main Boot: Version number of Main Boot.

■ Laminator Info

- ◆ Card Count: The total number of Cards passed through the Laminator.
- ◆ Total Count: The total amount of Laminates applied.
- ◆ Serial Number: Laminator SN.
- ◆ Model ID: Model ID.



For quality assurance at the factory, it is necessary to run various laminating tests on the laminator. A value of tens or more for Card Count is normal during manufacturing of your laminator.

■ Laminate Parm Setup

- ◆ **Laminate Mode:** Current laminate mode of the laminator. 8 different modes available. Mode 1 \ Mode 2 \ Mode 3 \ Mode 4 \ Mode 5 \ Mode 6 \ Mode 7 \ Mode 8
- ◆ **Heater Temp:** The temperature of the heating roller when laminating.
(Range: 100~180°C, Unit of adjustment: 5°C)
- ◆ **Laminate Speed:** The speed at which the card passes through the heating roller when laminating.
(Range: 5~35mm/s, Unit of adjustment :1mm/s)
- ◆ **Film Feed Speed:** Movement speed of Laminate after Laminate has been applied.
(Range: 9~35mm/s, Unit of adjustment: 1mm/s)
- ◆ **Film Laminate Pos:** After Black Mark detection, distance of Laminate is to be positioned.
(Range-80.0~80.0mm, Unit of adjustment: 0.1mm)
- ◆ **Card Laminate Pos:** Beginning position of Laminate on the Card when applied.
(Range: -10.0~10.0mm, Unit of adjustment: 0.1mm)
- ◆ **Laminate End Pos:** The distance from which the film continues to feed after laminating.
(Range: 0~80.0mm, Unit of adjustment: 0.1mm)
- ◆ **BlackMark Mode:** Used to detect the Black Mark on the Laminate.
Option: Disable \ Enable

- ◆ **BlackMark Detect Speed:** The feeding speed of Laminate when detecting the Black Mark.
(Range : 9~35mm/s, Unit of adjustment: 1mm/s)
- ◆ **Auto Card In:** The waiting time before loading the card when the card is detected.
(Range: 0~10s, Unit of adjustment: 1s)
- ◆ **Auto Laminate:** Turns on when used with DASCOM retransfer equipment and turns off when used alone.
Option: ON \ OFF



You can customize the parameters of the settings for each "Laminate Mode". When exiting the menu, the changed parameters will be saved. Directly select the corresponding "Laminate Mode" for various application.

■ Laminator Setup

- ◆ **Buzzer:** It sounds when there is a failure or alarm.
Option: OFF \ ON
- ◆ **Power Save Mode:** The laminator enters the power save mode after waiting for x minutes, and the temperature of the heating roller will be stable.
Option: Mode 1 \ Mode 2,
(Range: OFF 5~120min, Unit of adjustment: 1min)
- ◆ **Language Setup:** Sets the display font for the current LCD screen.
Option: CHINESE \ ENGLISH
- ◆ **LCD Contrast:** Adjust the contrast of the current LCD screen.
(Default: 128, Range: 0~255)
- ◆ **LCD Backlight:** Turns on or off the screen backlight.
Option: On \ Off

- ◆ **Laminate Type:** The currently recognized Laminate type.

Option: PATCH1 \ OVERLAY1

Setting	Function
Mode 1	In standby mode, it can be set to enter power save mode. The heating roller temperature drops to about 100°C.
Mode 2	In standby mode, it can be set to enter power save mode. The heating roller and LCD backlight are turned off to save energy.



Default is Mode 1. The laminator will enter Power Save Mode 1 after 30 min in standby mode.

■ Interface Setup

- ◆ **Laminator ID:** The device ID used to identify the laminator.
(Range: 0-15)
- ◆ **IP Type:** Method of obtaining a Network Address.
Option: Static \ Dynamic
- ◆ **IP Address:** The IP address of the laminator.
(Default: 192.168.0.12)
- ◆ **Subnet Mask:** The static subnet mask of the laminator.
(Default: 255.255.255.0)
- ◆ **Gateway:** The IP address of the static gateway of the laminator.
(Default: 192.168.0.1)
- ◆ **MAC Address:** Physical MAC address of the laminator.
- ◆ **Timeout(s):** The maximum time that network waits for the communication data.
(Default: 10s, Range: 0~255, Unit of adjustment: 1s)

■ Reset Default

Reset Factory Default Option: Yes \ No

CHAPTER 4 TROUBLESHOOTING

4.1 Warning Messages and Troubleshooting

This laminator is designed for minimal user intervention. Occasionally, the LCD displays messages to advise users to take corrective actions.

After clearing an error, press SET Key to initialize the laminator and [Ready] will be displayed.

- Warning/Error List

Display	Solution
Push Set Key	Press the SET Key once.
No Film	Check whether the film is installed or cut off.
Film Jam	Remove the film and reinstall it, to ensure correct installation.
Film End	The transfer film has been used up. Replace a new one.
Feeder Card Jam	Pressing Set Key as LCD display shown may eject jammed card. If the fault is still not cleared, turn the rollers manually to clear jammed card.
Invalid Parameter	Check whether each parameter of the menu setup item is within the setting range.
Heat Roll Failure	Check whether the heating roller is installed, and then contact your re-seller's service support team.
Device High Temp	Power off the laminator immediately.
HR Power Err	Contact your re-seller's service support team to report Error Code(s) displayed on the lower right of LCD.
Call Support	Contact your re-seller's service support team to report Error Code(s) displayed on the lower right of LCD.

DASCOM REPRESENTATIVES

GERMANY

DASCOM Europe GmbH
Heuweg 3
89079 Ulm
Germany
Tel.: +49 (0) 731 2075 0
Fax: +49 (0) 731 2075 100
www.dascom.com

UNITED KINGDOM

DASCOM GB Ltd
Hart House, Priestley Road,
Basingstoke, Hampshire
RG24 9PU, England
Phone: +44 (0) 1256 355130
Fax: +44 (0) 1256 481400
www.dascom.com

SINGAPORE (ASIA PACIFIC)

DASCOMAP Pte Ltd
2 Jurong East Street 21
05-42, IMM Building
Singapore 609601
Phone: +65 6760 8833
Fax: +65 6760 1066
www.dascom.com

AMERICAS

DASCOM Americas Corporation
34 Lakeview Court
Verona, VA 24482
USA
Phone: +1 (877) 434 1377
Fax: +1 (877) 334 0549
www.dascom.com

FRANCE

DASCOM Europe GmbH
7, Impasse de la Chanée
77410 Annet Sur Marne
France
Phone: +33 (1) 85 42 24 00
www.dascom.com

CHINA

JIANGMEN DASCOM
COMPUTER
PERIPHERALS CO., LTD
No.399, Jinxing Road,
Jianghai District Jiangmen,
P.R. China
www.dascom.com

All rights reserved. Translations, reprinting or copying by any means of this manual complete or in part or in any different form requires our explicit approval. We reserve the right to make changes to this manual without notice. All care has been taken to ensure accuracy of information contained in this manual. However, we cannot accept responsibility for any errors or damages resulting from errors or inaccuracies of information herein.

©2025 DASCOM